



МАРТ

E-MART
ВАШ ПОСТАВЩИК
DAHUA

<https://emart.su/brands/dahua/>

Федеральный	8 800 511-77-41
Санкт-петербург	8 812 426-99-66
Москва	8 495 137-99-67
Краснодар	8 861 205-62-66

www.emart.su

mail@emart.su

DHI-ARD311-W

Wireless Door/Window Contact



Features

- Door/Window sensor, 25-40mm motion distance
- Bi-directional communication
- Up to 700m transmission distance (open space/no interference)
- 3 years battery life
- Tamper switch equipped
- Screw or glue to mount
- ABS plastic

Technical Specifications

Model	DHI-ARD311-W
Name	Wireless door sensor
Motion distance	25-40mm
Alarm prompt	Notification LED light, can be set to switch off
Wireless Frequency	433MHz
Transmit Power	10dBm
Transmit Distance	700m (open area/no interference)
Tamper	Front cover and rear cover protection
Power	1xCR123A battery, 3V 50mA
Installation Way	Screw and glue
Dimensions	84*39*22mm (L*W*H)

DHI-ARD311-W

Weight	0.1kg
Temperature	-10°C~50°C
Humidity	< 95%
Installation	Screw or glue to mount

Product Appearance

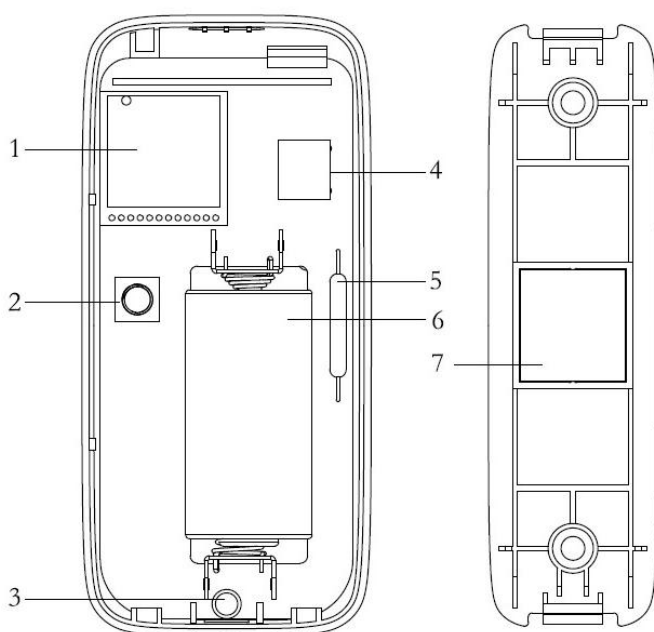

No.	Note
1	Wireless module
2	Vandal-proof switch I (case)
3	LED
4	Vandal-proof II (wall vandal-proof)
5	Reed switch
6	Battery
7	Magnetic

Figure 1- 1

DHI-ARD311-W

Dimensions

